

Graphic reference

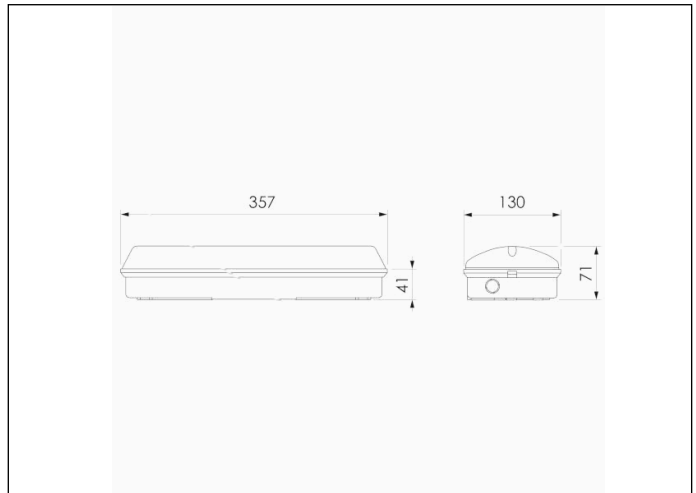

Dimensions



Control System: AutoTest
Centralized Wireless

Luminaire: Self-Contained

Standards: EN-60598-1,
EN-60598-2-22, EN-62034

Certification: CE, ENEC



Electrical characteristics

Supply: 230V 50Hz<7.5W

Maintained mode consumption: 7.5 W

Non-maintained mode consumption: 2.0 W

Working temperature: 0-40°C

Emergency lamp: 12 x LED 0.5W

Emergency lumen output: 795 lm

Maintained lumen output: 400 lm

Battery: 6.4V-1.5Ah LFP

Class: II

Mode: M/NM

Power factor: - %

Signaling Luminaire: -

LED temperature: 4000°K

Duration: 1 h

Remote control: No

Charging time: 12 h

Mechanical characteristics

Envelope: Polycarbonate

Diffuser: Matted Polycarbonate

Suitable for flammable surfaces: Yes

ATEX Envelope:

IP/IK: IP65/IK10

Finish: White RAL9003

Weight: 1,00KG

Photometric curve

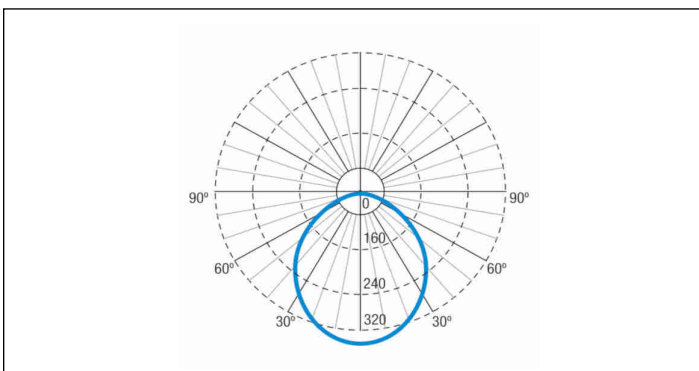

Interdistance

Installation height



2,0 m 10,51 m 10,51 m

2,5 m 13,13 m 13,13 m

3,0 m 14,61 m 14,61 m

3,5 m 15,65 m 15,65 m

Installation characteristics

Maintained luminaires use 3 terminals to enable / disable the maintained mode.
Installation with mounting plate.
Possibility of installation in:
 Ceiling/Wall surface.
Possibility of connection with:
 Surface tube wiring.
It has 3 pre-marked entries for PG-11 cable glands (not included), for mounting with surface pipe.

Operating characteristics

The luminaire has status LEDs, which indicates:
 Status of the battery charging circuit.
 Battery status (duration)
 Emergency status function.
 Test status.
Microprocessor controlled luminaire
The luminaire can be connected to a control unit.
When the luminaire is installed without a control unit, it performs periodic and automatic tests.
 Functional test every 7 days.
 Duration test every 365 days.
The test result is shown in the status indicator LEDs.
Wireless communication that allows: Communication with Control unit by wireless communication with a 868Mhz frequency system.

General Envelope data

Accessories

ADBA008



ACC. DIF. PANEL ARIAN WHITE
WITHOUT SERIG.

APA818



ACC. PICTO. ARIAN PERSON +UP
ARROW

AGA230



ACC. PROTEC. GRILLE ARIAN