

Graphic reference

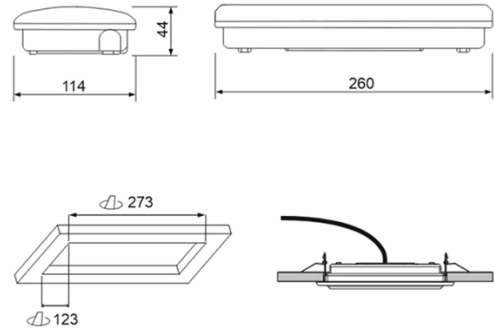

Dimensions



Control System: SmartZ

Luminaire: Self-Contained

Standards: EN-60598-1,
EN-60598-2-22, EN-62034,
ETSI EN 303 446-1 V1.2.1

Certification: CE



Electrical characteristics

Supply: 230V 50Hz<2.5W

Maintained mode consumption: 2,5 W

Non-maintained mode consumption: 0,9 W

Working temperature: 0-40°C

Emergency lamp: 12xLED 0.5W

Emergency lumen output: 150 lm

Maintained lumen output: 90 lm

Battery: 3.2V-1.5Ah LFP

Class: II

Mode: -

Power factor: - %

Signaling Luminaire: -

LED temperature: 4000°K

Duration: 3 h

Remote control: No

Charging time: 12 h

Mechanical characteristics

Housing: Polycarbonate

Diffuser: Transfresnel Polycarbonate

Suitable for flammable surfaces: Yes

ATEX Envelope:

IP/IK: IP44/IK07

Finish: White RAL9003

Weight: 0,58KG

Photometric curve

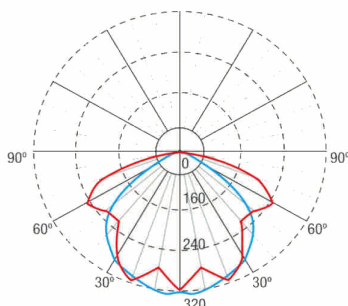

Interdistance

Installation height



2,0 m	9,14 m	6,72 m
2,5 m	9,84 m	7,61 m
3,0 m	10,34 m	8,34 m
3,5 m	10,27 m	8,95 m

Installation characteristics

Maintained luminaires have a selector bridge to enable / disable the maintained mode.

Installation with mounting plate.

Possibility of installation in:

- Ceiling/Wall surface.

- Recessed in ceiling.

- Semi-recessed in wall.

Possibility of connection with:

- Recessed wiring.

- Surface tube wiring (max. M20)

Operating characteristics

The luminaire has status LEDs, which indicates:

- Status of the battery charging circuit.

- Battery status (duration)

- Emergency status function.

- Test status.

Microprocessor controlled luminaire

The luminaire can be connected to a control unit.

When the luminaire is installed without a control unit, it performs periodic and automatic tests.

- Functional test every 7 days.

- Duration test every 365 days.

The test result is shown in the status indicator LEDs.

Wireless communication that allows: Communication with Control unit by wireless communication with a 2.4Ghz frequency system.

General Envelope data

Accessories

AMD0051



ACC. REC. DIANA FLAT WHITE
CEILING

90091NMF



ACC. PANEL REC. DIANA FLAT WHITE
CEILING

APE0065



ACC. HOUSING IP66 DIANA FLAT
WHITE

APE144



ACC. HOUSING IP44 DIANA FLAT
WHITE

AED0071



ACC. SEMI-REC. DIANA FLAT WHITE
WALL

AMU8001



ACC. FRAME REC. DIANA/XENA
WHITE UNIVERSAL

AIF001



ACC. SLOPE 47° FLAT WHITE

AKF001



ACC. PROT. IK10 FLAT WHITE

AGV120



ACC. PROTEC. GRILLE FLAT/VENUS