

Graphic reference

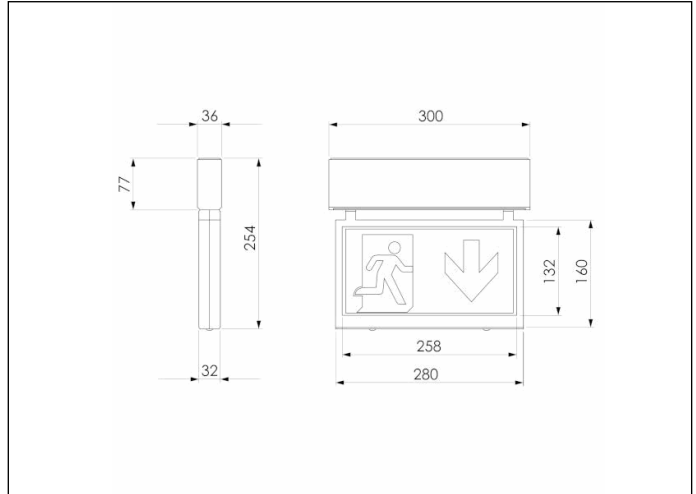

Dimensions



Control System: AutoTest
Centralized Wireless
Standards: EN-60598-1,
EN-60598-2-22, EN-62034

Luminaire: Self-Contained
Certification: CE

Electrical characteristics

Supply: 230V 50Hz<3.6W
Maintained mode consumption: 3.6 W
Non-maintained mode consumption: - W
Working temperature: 0-40°C
Emergency lamp: 8xLEDS 0.5W
Emergency lumen output: - lm
Maintained lumen output: - lm
Battery: 3.2V-1.5Ah LFP

Class: II
Mode: M
Power factor: - %
Signaling Luminaire: -
LED temperature: 4000°K
Duration: 3 h
Remote control: No
Charging time: 12 h

Mechanical characteristics

Envelope: Polycarbonate
Diffuser: Methacrylate
Suitable for flammable surfaces: Yes

IP/IK: IP42/IK04
Finish: Gray RAL9006
Weight: 0,87KG

ATEX Envelope:

Photometric curve



Interdistance

Installation height

2,0 m
2,5 m
3,0 m
3,5 m



-
-
-
-

Installation characteristics

Installation with mounting plate.

Possibility of installation in:

Ceiling surface.

Wall mural.

Wall flag.

Possibility of connection with:

Surface tube wiring.

Vision distance: 25,8 m

Operating characteristics

The luminaire has status LEDs, which indicates:

Status of the battery charging circuit.

Battery status (duration)

Emergency status function.

Test status.

Microprocessor controlled luminaire

The luminaire can be connected to a control unit.

When the luminaire is installed without a control unit, it performs periodic and automatic tests.

Functional test every 7 days.

Duration test every 365 days.

The test result is shown in the status indicator LEDs.

Wireless communication that allows: Communication with Control unit by wireless communication with a 868Mhz frequency system.

General Envelope data