

Graphic reference

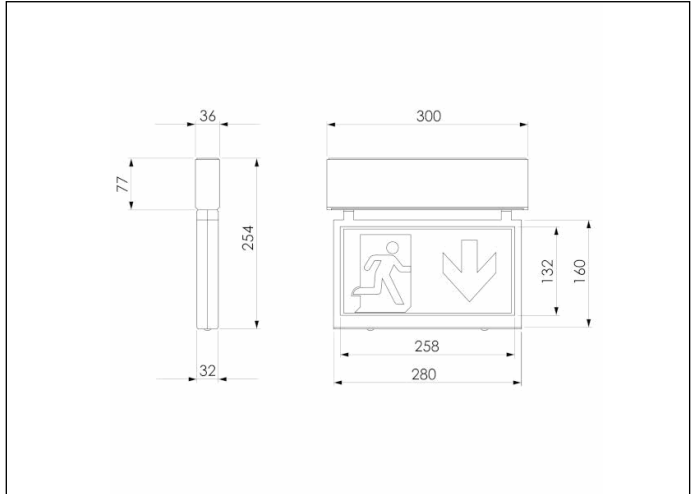

Dimensions



Control System: SmartZ

Luminaire: Self-Contained

Standards: EN-60598-1,
EN-60598-2-22, EN-62034,
ETSI EN 303 446-1 V1.2.1

Certification: CE

Electrical characteristics

Supply: 230V 50Hz<4.0W

Maintained mode consumption: 4,0 W

Non-maintained mode consumption: - W

Working temperature: 0-40°C

Emergency lamp: 8xLEDS 0.5W+2xLEDS 3W

Emergency lumen output: 120 lm

Maintained lumen output: 70 lm

Battery: 3.2V-3.0Ah LFP

Class: II

Mode: M

Power factor: - %

Signaling Luminaire: -

LED temperature: 4000°K

Duration: 3 h

Remote control: No

Charging time: 12 h

Mechanical characteristics

Housing: Polycarbonate

Diffuser: Methacrylate

Suitable for flammable surfaces: Yes

ATEX Envelope:

IP/IK: IP42/IK04

Finish: Grey RAL9006

Weight: 0,87KG

Photometric curve



Interdistance

Installation height



2,0 m

6,93 m

6,20 m

2,5 m

7,69 m

7,06 m

3,0 m

8,30 m

7,77 m

3,5 m

8,77 m

8,34 m

Installation characteristics

Installation with mounting plate.

Possibility of installation in:

Ceiling surface.

Wall mural.

Wall flag.

Possibility of connection with:

Surface tube wiring.

Vision distance: 25,8 m

Operating characteristics

The luminaire has status LEDs, which indicates:

Status of the battery charging circuit.

Battery status (duration)

Emergency status function.

Test status.

Microprocessor controlled luminaire

The luminaire can be connected to a control unit.

When the luminaire is installed without a control unit, it performs periodic and automatic tests.

Functional test every 7 days.

Duration test every 365 days.

The test result is shown in the status indicator LEDs.

Wireless communication that allows: Communication with Control unit by wireless communication with a 2.4Ghz frequency system.

General Envelope data