

Graphic reference

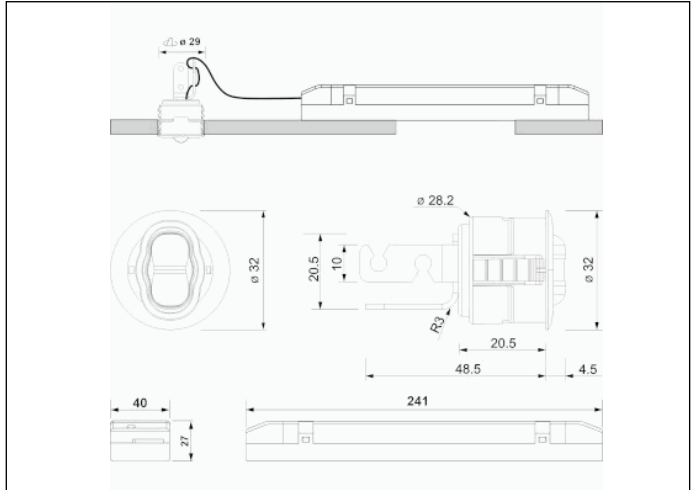

Dimensions



Control System: SmartZ

Luminaire: Self-Contained

Standards: EN-60598-1,
EN-60598-2-22, EN-62034,
ETSI EN 303 446-1 V1.2.1

Certification: CE

Electrical characteristics

Supply: 230V 50Hz<2.5W

Maintained mode consumption: 2,5 W

Non-maintained mode consumption: 0,9 W

Working temperature: 0-40°C

Emergency lamp: 1 x LED 3W

Emergency lumen output: 165 lm

Maintained lumen output: 100 lm

Battery: 3.2V-1.8Ah LFP

Class: II

Mode: M/NM

Power factor: - %

Signaling Luminaire: -

LED temperature: 4000°K

Duration: 3 h

Remote control: No

Charging time: 12 h

Mechanical characteristics

Housing: Polycarbonate

Diffuser: Escape Lens

Suitable for flammable surfaces: Yes

ATEX Envelope:

IP/IK: IP42/IK04

Finish: White RAL9003

Weight: 0,21KG

Photometric curve

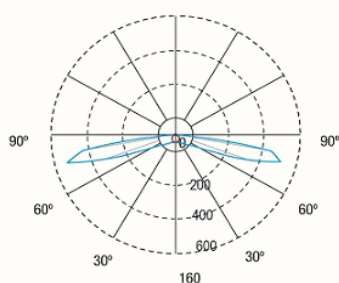

Interdistance

Installation height

Installation height	Interdistance	Interdistance
2,0 m	6,36 m	21,46 m
2,5 m	6,70 m	24,63 m
3,0 m	6,88 m	24,99 m
3,5 m	6,89 m	26,22 m

Installation characteristics

Maintained luminaires use 3 mains supply inputs (L, L1, N) to enable / disable the maintained mode.

Luminaires made up of a spotlight + electrical equipment with batteries (Self-contained luminaires).

Possibility of installation in:

- On suspended ceiling.

- Recessed ceiling (Slat ceilings) with accessory (included).

- Continuous rail.

Operating characteristics

The luminaire has status LEDs, which indicates:

- Status of the battery charging circuit.

- Battery status (duration)

- Emergency status function.

- Test status.

Microprocessor controlled luminaire

The luminaire can be connected to a control unit.

When the luminaire is installed without a control unit, it performs periodic and automatic tests.

- Functional test every 7 days.

- Duration test every 365 days.

The test result is shown in the status indicator LEDs.

Wireless communication that allows: Communication with Control unit by wireless communication with a 2.4Ghz frequency system.

General Envelope data