

### Graphic reference

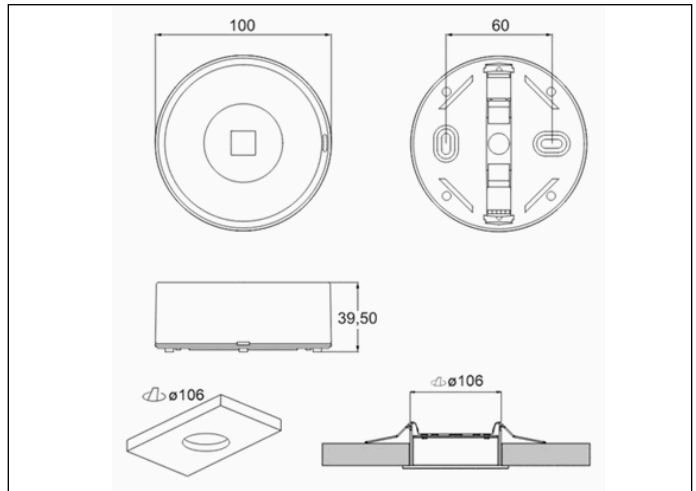

### Dimensions



**Control System:** SmartZ

**Luminaire:** Self-Contained

**Standards:** EN-60598-1,  
EN-60598-2-22, EN-62034,  
ETSI EN 303 446-1 V1.2.1

**Certification:** CE



### Electrical characteristics

**Supply:** 230V 50Hz<2.5W

**Maintained mode consumption:** 2,5 W

**Non-maintained mode consumption:** 0,9 W

**Working temperature:** 0-40°C

**Emergency lamp:** 1 x LED 3W

**Emergency lumen output:** 165 lm

**Maintained lumen output:** 100 lm

**Battery:** 3.2V-1.8Ah LFP

**Class:** II

**Mode:** M/NM

**Power factor:** - %

**Signaling Luminaire:** -

**LED temperature:** 4000°K

**Duration:** 3 h

**Remote control:** No

**Charging time:** 12 h

### Mechanical characteristics

**Housing:** Polycarbonate

**Diffuser:** Hall Lens / Wall

**Suitable for flammable surfaces:** Yes

**ATEX Envelope:**

**IP/IK:** IP42/IK04

**Finish:** White RAL9003

**Weight:** 0,19KG

### Photometric curve

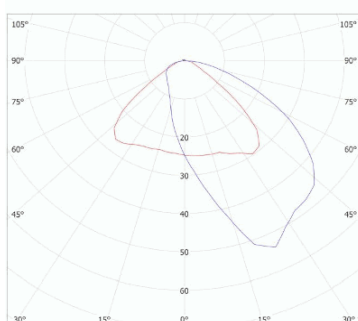

### Interdistance

**Installation height**



2,0 m	8,17 m	6,40 m
2,5 m	9,03 m	7,30 m
3,0 m	9,69 m	8,17 m
3,5 m	10,22 m	8,95 m

### Installation characteristics

Non-maintained luminaires use 4 terminals (2xL + 2xN) for supply connection.  
Maintained luminaires use 5 terminals (2xL + 2xN + L1) to enable / disable the maintained mode.  
Installation with mounting plate.  
Possibility of installation in:  
    Wall surface.  
Possibility of connection with:  
    Recessed wiring.  
    Surface tube wiring (max. M20)  
Luminaire designed to be installed at high heights (>5m)

### Operating characteristics

The luminaire has status LEDs, which indicates:  
    Status of the battery charging circuit.  
    Battery status (duration)  
    Emergency status function.  
    Test status.  
Microprocessor controlled luminaire  
The luminaire can be connected to a control unit.  
When the luminaire is installed without a control unit, it performs periodic and automatic tests.  
    Functional test every 7 days.  
    Duration test every 365 days.  
The test result is shown in the status indicator LEDs.  
Wireless communication that allows: Communication with Control unit by wireless communication with a 2.4Ghz frequency system.

### General Envelope data

### Accessories

#### ALE0065



ACC. HOUSING IP65 SPAZIO LUZ  
WHITE

#### ALT0011



ACC. INPUT FLEX. SPAZIO LUZ  
WHITE SURFACE TUBE 20MM  
CONDUIT KIT