

Graphic reference

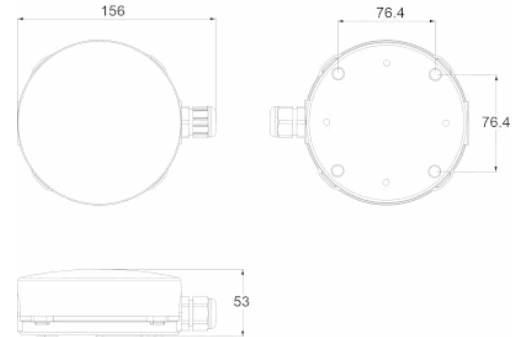

Dimensions



Control System: AutoTest

Luminaire: Self-Contained

Standards: EN-60598-1,
EN-60598-2-22, EN-62034

Certification: CE

Electrical characteristics

Supply: 230V 50Hz<3.8W

Maintained mode consumption: 3,8 W

Non-maintained mode consumption: 0,9 W

Working temperature: -10°C / 40°C

Emergency lamp: 12xLED 0.5W

Emergency lumen output: 425 lm

Maintained lumen output: 250 lm

Battery: 3.2V-1.5Ah LFP

Class: II

Mode: M/NM

Power factor: - %

Signaling Luminaire: -

LED temperature: 4000°K

Duration: 1 h

Remote control: No

Charging time: 12 h

Mechanical characteristics

Housing: Polycarbonate

Diffuser: Transparent Polycarbonate

Suitable for flammable surfaces: Yes

ATEX Envelope:

IP/IK: IP65/IK10

Finish: White RAL9003

Weight: 0,30KG

Photometric curve

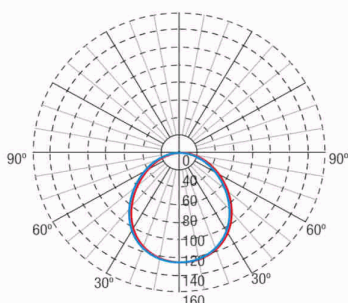

Interdistance

Installation height



2,0 m	9,80 m	9,78 m
2,5 m	10,98 m	10,96 m
3,0 m	11,92 m	11,91 m
3,5 m	12,33 m	12,31 m

Installation characteristics

Non-maintained luminaires use 4 terminals (2xL + 2xN) for supply connection.
Maintained luminaires use 5 terminals (2xL + 2xN + L1) to enable / disable the maintained mode.
Installation with mounting plate.
Possibility of installation in:
 Ceiling/Wall surface.
Possibility of connection with:
 Surface tube wiring (max. M20)

Operating characteristics

Charge in 24 h to obtain the nominal duration of the luminaire.
The luminaire has status LEDs, which indicates:
 Status of the battery charging circuit.
 Battery status (duration)
 Emergency status function.
 Test status.
Microprocessor controlled luminaire that performs periodic and automatic tests.
 Functional test every 7 days.
 Duration test every 365 days.
The test result is shown in the status indicator LEDs.
The luminaire has a built-in button, which allows:
 Simulation test of supply failure.
Remote control input that allows:
 Standby without power supply.
 Resumed in emergency status without power supply.
 Switched on in emergency status (more than 24 h of charge)
 Manual and remote duration test. (more than 24 hours of charge).
 Date and time programming of the tests.

General Envelope data