

### Graphic reference

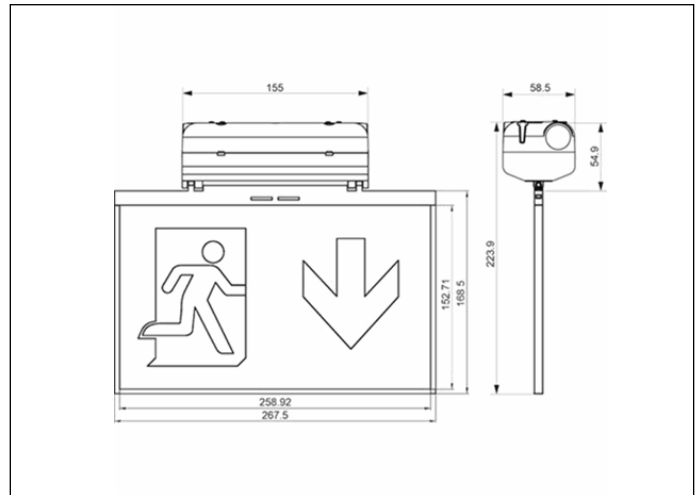

### Dimensions



**Control System:** SmartZ

**Luminaire:** Self-Contained

**Standards:** EN-60598-1,  
EN-60598-2-22, EN-62034,  
ETSI EN 303 447-1

**Certification:** CE



### Electrical characteristics

**Supply:** 230V 50Hz<3.6W

**Maintained mode consumption:** 2.9 W

**Non-maintained mode consumption:** - W

**Working temperature:** 0-40°C

**Emergency lamp:** 25xLED 0.5W

**Emergency lumen output:** - lm

**Maintained lumen output:** - lm

**Battery:** 3.2V-1.5Ah LFP

**Class:** II

**Mode:** M

**Power factor:** - %

**Signaling Luminaire:** -

**LED temperature:** 6500°K

**Duration:** 3 h

**Remote control:** No

**Charging time:** 12 h

### Mechanical characteristics

**Housing:** Polycarbonate

**Diffuser:** Methacrylate

**Suitable for flammable surfaces:** Yes

**ATEX Envelope:**

**IP/IK:** IP42/IK04

**Finish:** White RAL9003

**Weight:** 0,16KG

### Photometric curve

### Interdistance

**Installation height**



2,0 m

-

-

2,5 m

-

-

3,0 m

-

-

3,5 m

-

-

### Installation characteristics

Maintained luminaires use 4 terminals (2xL + 2xN).  
Installation with mounting plate.  
Possibility of installation in:  
    Ceiling/Wall surface.  
Possibility of connection with:  
    Surface tube wiring.  
Vision distance: 25 m

### Operating characteristics

The luminaire has status LEDs, which indicates:  
    Status of the battery charging circuit.  
    Battery status (duration)  
    Emergency status function.  
    Test status.

Microprocessor controlled luminaire  
The luminaire can be connected to a control unit.  
When the luminaire is installed without a control unit, it performs periodic and automatic tests.  
    Functional test every 7 days.  
    Duration test every 365 days.

The test result is shown in the status indicator LEDs.  
Wireless communication that allows: Communication with Control unit by wireless communication with a 868Mhz frequency system.

### General Envelope data