

Graphic reference

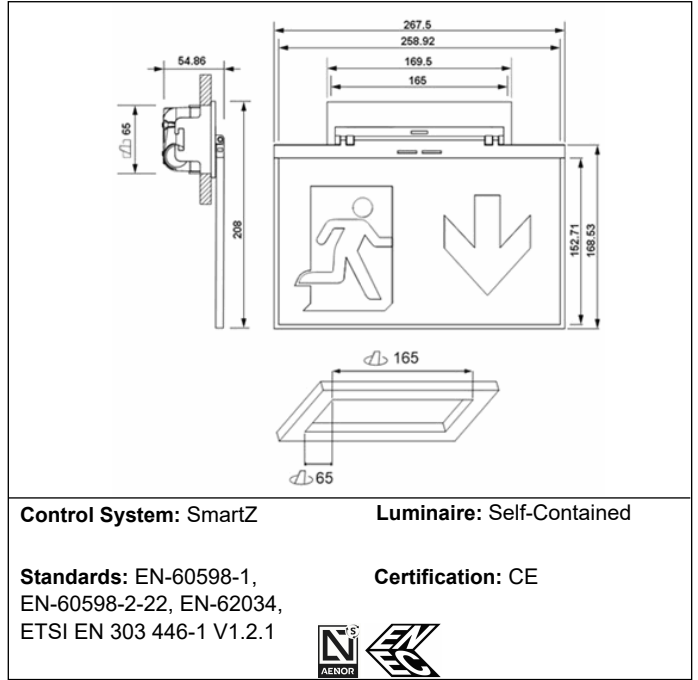

Dimensions



Electrical characteristics

<p>Supply: 230V 50Hz<3.6W</p> <p>Maintained mode consumption: 3,6 W</p> <p>Non-maintained mode consumption: - W</p> <p>Working temperature: 0-40°C</p> <p>Emergency lamp: 25xLED 0.5W</p> <p>Emergency lumen output: - lm</p> <p>Maintained lumen output: - lm</p> <p>Battery: 3.2V-1.5Ah LFP</p>	<p>Class: II</p> <p>Mode: M</p> <p>Power factor: - %</p> <p>Signaling Luminaire: -</p> <p>LED temperature: 4000°K</p> <p>Duration: 3 h</p> <p>Remote control: No</p> <p>Charging time: 12 h</p>
--	---

Mechanical characteristics

<p>Housing: Polycarbonate</p> <p>Diffuser: Methacrylate</p> <p>Suitable for flammable surfaces: Yes</p> <p>ATEX Envelope:</p>	<p>IP/IK: IP42/IK04</p> <p>Finish: White RAL9003</p> <p>Weight: 0,48KG</p>
---	---

Photometric curve



Interdistance

Installation height		
2,0 m	-	-
2,5 m	-	-
3,0 m	-	-
3,5 m	-	-

Installation characteristics

Maintained luminaires use 4 terminals (2xL + 2xN).
Installation with mounting plate.
Possibility of installation in:
 Recessed ceiling.
Possibility of connection with:
 Surface tube wiring.
Vision distance: 25 m

Operating characteristics

The luminaire has status LEDs, which indicates:
 Status of the battery charging circuit.
 Battery status (duration)
 Emergency status function.
 Test status.
Microprocessor controlled luminaire
The luminaire can be connected to a control unit.
When the luminaire is installed without a control unit, it performs periodic and automatic tests.
 Functional test every 7 days.
 Duration test every 365 days.
The test result is shown in the status indicator LEDs.
Wireless communication that allows: Communication with Control unit by wireless communication with a 2.4Ghz frequency system.

General Envelope data